



Avid HD Workflows



Table of Contents

| | |
|--|----|
| Introduction..... | 1 |
| Avid and HD..... | 1 |
| HDV workflow..... | 3 |
| HD workflow overview..... | 4 |
| Offline/Online workflow..... | 5 |
| Film-based television and feature film workflow..... | 6 |
| Real-time collaboration with HD resolution..... | 7 |
| Creative editorial versus mastering..... | 8 |
| Other workflow enablers..... | 8 |
| Appendix A - Project types for Media Composer®..... | 10 |
| Appendix B - Avid DNxHD® family of resolutions..... | 11 |

Introduction

2004 was the year high-definition (HD) hit the mainstream, now HD is truly here. Japan has led the worldwide charge, with the US close behind. The major US networks now have HD broadcast channels or are broadcasting HD during the primetime hours. Cable and satellite providers are offering HD at low cost. Sales of HD screens to consumers have exploded as sets hit magic price points.

On the production front, even productions without current HD broadcast requirements are choosing to master in HD, ensuring a high-quality master for future content repurposing. The high definition consumer formats have been set, with Blu-ray players on the market as well as web based HD streaming and downloads starting to become available.

The popularity of HD is also growing because a wider range of acquisition products are now available. New prosumer cameras that support the HDV format have recently been introduced, while higher-end HD resolutions, including 4:4:4 HD-RGB can now be achieved with HDCAM SR-capable cameras. Add these acquisition methods to the widely used HDCAM, XDCAM HD and DVCPRO HD camera formats, and HD can now be acquired at data rates that scale from 25 megabits per second (HDV) to 880 megabits per second (HDCAM-SR), making HD a reality across the industry and in all markets.

HD is now used in a variety of ways, from acquisition to post production to delivery. This affects a wide range of workflow practices and metadata management requirements. To help customers navigate a changing environment, Avid supports a wide assortment of complete HD workflow solutions.

Avid and HD

Avid has become an established leader in the HD arena by providing universal HD support in its editing systems, and by delivering workflow solutions that streamline HD production pipelines. Avid® DS has led the way with high quality uncompressed 10-bit HD with real-time two stream playback as well as support for even higher quality 10-bit HD-RGB. Avid Media Composer systems, Symphony™ systems, NewsCutter® systems and Avid Unity™ products have HD capabilities. It is a continued design goal to provide scaleable solutions – from editorial to finishing and mastering with increased capabilities in workgroup environments.

Highly efficient workflows depend on more than the playback performance of a single system; sharing of media and metadata management are critical in many environments where performance is judged not only on stream count, but on overall efficiency of completing programs in a multi-seat distributed collaborative environment.

Historically, simultaneous sharing and playback of multiple stream HD media has been impossible due to the enormous size of uncompressed HD files. That reality has changed, however, with the introduction of Avid DNxHD – highly efficient encoding that provides mastering-quality HD media in small file sizes.

Powered by Avid DNxHD, Media Composer Mojo® DX, Media Composer Nitris DX, Symphony Nitris DX and DS systems can share the same mastering-quality HD content simultaneously - in real-time - in an Avid Unity environment. Avid DNxHD encoding is even available in the software version of Avid Media Composer that's ideal for portable HD editing on a notebook.

Avid DNxHD encoding allows customers more choices when building workflows because it is the first codec compliant with SMPTE-VC3. With more than 30 partners licensing Avid DNxHD technology workflows can be extended throughout the facility across multiple manufacturers, providing solutions to meet any need. This compliance also delivers the availability of a new standard for mapping VC-3 coding units into MXF – making Avid DNxHD encoding the professional standard for file exchange, creative editorial and mastering, and data archiving.

Avid DNxHD encoding is licensable through the Avid Website to any user who wants to compile it on any platform (www.avid.com/DNxHD).

But, it is also understood that solution flexibility is key to a successful business and customers will decide what is best for their program and downstream deliverables; compressed or uncompressed, SD or HD. Avid provides scalable solutions for all of these workflows in both standalone and large enterprise size workgroups, at any resolution. From smaller, high bandwidth shared workgroups using Avid Unity MediaNetwork to enterprise level Avid Unity ISIS®, productions will always find an entry point and a growth path within the Avid family of products.

From acquisition to delivery, many more solutions are possible in Avid environments that are not possible with other systems. Avid enables these highly efficient workflows through superior metadata management, such as multiple source timecodes, sound timecode, and film KeyKode for all captured sources. For example, by tracking audio

timecode from the set in addition to the timecode used for picture, Avid systems can easily synchronize the two in post production, creating a new source clip, yet still keeping track of the original sources for downstream processes.

Tracking multiple incarnations of an image as it transforms from film to HD to SD to files in a workgroup environment requires new efficiencies in asset management. From proxy offline browsing on a laptop to real time uncompressed HD based playback in a shared storage environment, productivity depends on the ability to track history of sources as well as target formats. This level of media management in a mixed-resolution environment, with the ability to integrate seamlessly into existing workflows, is exclusive to Avid's offerings.

Productions will choose formats based on budget considerations, creative choices, and delivery requirements. Because of the myriad of choices facing production, HD workflows can be as simple as "capture, edit, output" with FireWire® based HD formats such as HDV and DVCPRO HD. Or they can be more complex, with mixed formats and resolutions in shared collaborative environment. The workflows discussed in this whitepaper should be considered as basic starting points: the basis for a completely new workflow design as productions make the transition from SD to HD.

HDV workflow

When working with HDV media, capturing and editing in its native long-GOP MPEG2 format is critical. Systems that can't handle native HDV must transcode to another format, delaying the time it takes to start editing by double both the import time and storage space while possibly compromising image quality. Avid supports native HDV formats in all its editing solutions. Long-GOP splicing allows unmodified native media to flow directly back into the final output stream with no generation loss. The workflow with HDV media is straightforward and mimics the widely used DV25 workflow. Media is captured over IEEE 1394 (FireWire) directly into the editing application. Deck control, picture, and sound are all controlled over this single connection. As shown in the diagram below, the production and post-production processes are self contained, but the final output may be varied depending on the client's distribution needs.

With HDV projects, Avid offers the best of both worlds. Cuts-only sections of the project remain native HDV: storage-efficient, original digital quality. But native long-GOP MPEG-2 HDV is not ideal for sections with effects, compositing and titles because quality can suffer. So for these sections, Avid takes advantage of mastering-quality Avid DNxHD

encoding. The result is a final project with the best possible quality, performance and storage efficiency. If long-GOP MPEG-2 (HDV) is needed as one of the output streams, GOP splicing ensures only the modified or newly created elements of the final sequence will be encoded.

In addition to the long-GOP MPEG-2 format, the user can also prepare the sequence for other types of output. Avid's Mojo DX and Nitris DX hardware solutions can output uncompressed- HD over the HD-SDI to a compatible HD VTR, or can perform real-time down convert to standard definition (SD) via SDI. Direct export of WMV HD (Windows Media at high definition) and H.264 can be used to prepare the HD sequence for online streaming, digital cinema or high definition DVD.

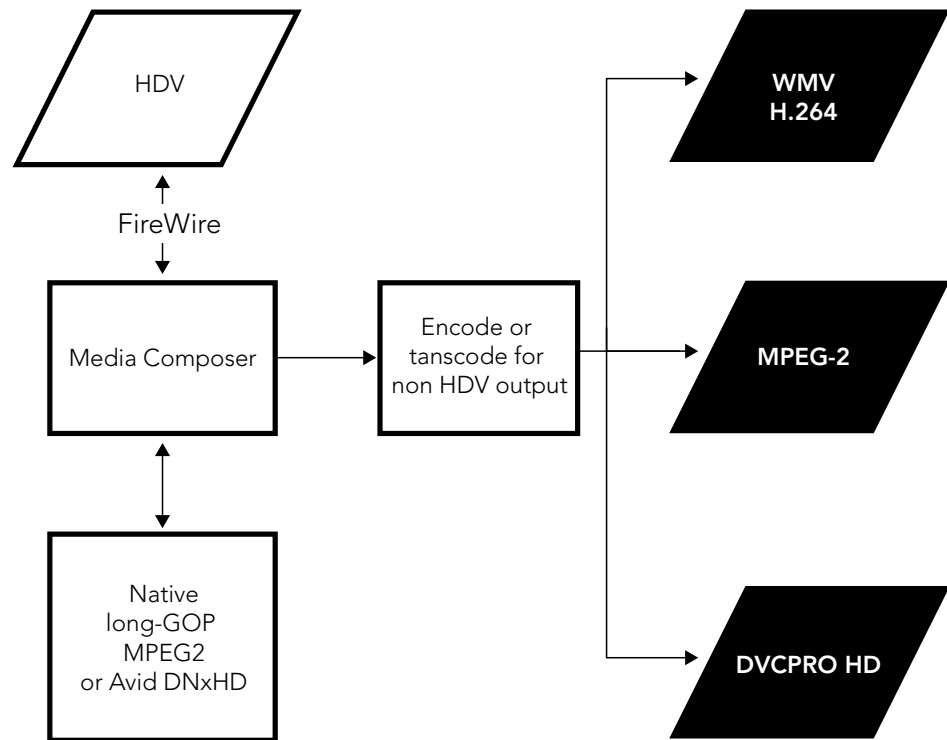

HD workflow overview

To fulfill their HD acquisition, storage, and distribution needs, users have the flexibility to choose from a full range of Avid solutions. An HD workflow can be as simple as the one outlined using HDV or it can be much more complex, such as that for high end television or feature films.

Avid HD solutions range from uncompressed 10-bit HD-RGB to the high-quality efficient resolutions of the Avid DNxHD family. The data rates of the Avid DNxHD resolutions compare to those of uncompressed standard definition video. Because of this, the

infrastructure needed to support HD will be very similar to that needed to support standard definition. This efficiency translates into easy to configure standalone HD storage systems, or high-performing collaborative solutions when connected to Avid Unity shared media networks.

The basic workflows for each situation are discussed below, and users can build on them to fit their particular needs.

Offline/Online workflow

There are several factors that will determine the need for an offline versus online situation, such as: amount of footage, time to deliver final program, and storage budget. For instance, even though the cost of high-quality HD acquisition has been reduced, productions tend to shoot more than ever before, ultimately increasing the amount of total footage. Efficient processes are therefore needed for post production, such as an offline process with a recapture for the online finish.

The below diagram shows 1080p/23.976 HD offline workflow with a Media Composer Nitris DX system. The same processes are used for all frame rates

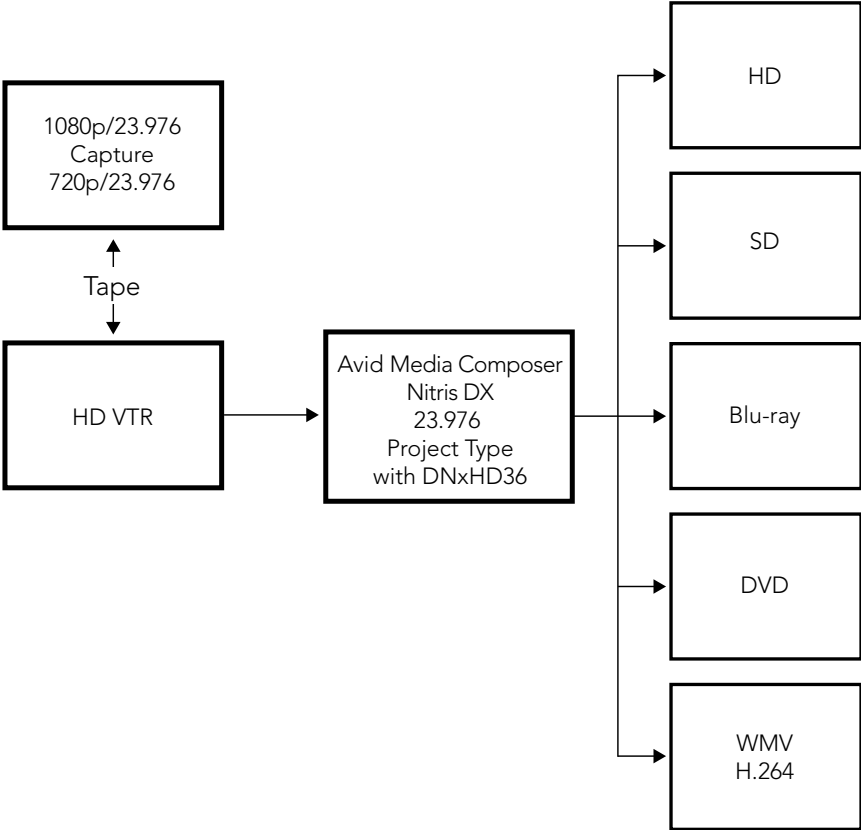

When the offline is complete, the user can recapture the material using Avid DNxHD for finishing and mastering. Avid DNxHD maintains the camera-original resolution, raster, frame rate, and aspect ratio so quality is maintained: no artifacts are introduced due to resize, interlace/de-interlace or frame-rate conversion. Users can also choose target file size / bit depth. A good guideline is to use the Avid DNxHD variant that matches the megabit data rate of the acquisition format being shot. So for HDCAM originated material, the user will be using Avid DNxHD 145, which closely matches the data rate of HDCAM, but provides a far better image quality and is far better suited for color correction and effects multi-generational renders. Users that are sourcing from D5 will most likely gravitate towards Avid DNxHD 220 or Avid DNxHD 220x, 8-bit and 10-bit versions of the Avid DNxHD codec. The end result will be better mastering results using less storage capacity.

It is easy to correlate Avid DNxHD to existing HD formats when making a decision as to what Avid DNxHD format to use based on acquisition format:

| Format | Avid DNxHD 36 | Avid DNxHD 145 | Avid DNxHD 220 | Panasonic D5 | DVCPRO HD | HDCAM | HDCAM SR |
|------------------|----------------------|-----------------------|-----------------------|---------------------|------------------|--------------|--------------------------|
| Bit Depth | 8-bit | 8-bit | 8- and 10-bit | 8- and 10-bit | 8-bit | 8-bit | 10-bit |
| Sampling | 4:2:2 | 4:2:2 | 4:2:2 | 4:2:2 | 4:2:2 | 3:1:1 | 4:2:2 or 4:4:4 |
| Bandwidth | 36 Mb/sec | 145 Mb/sec | 220 Mb/sec | 220 Mb/sec | 100 Mb/sec | 135 Mb/sec | 440 Mb/sec Or 880 Mb/sec |

Uncompressed HD for the most demanding productions is available on Avid DS, Avid Symphony Nitris DX, Media Composer Nitris DX and Media Composer Mojo DX. These systems all offer the industry's best performing 10-bit uncompressed HD solution on the market today. In addition, Avid DS offers the added benefit of support for 4:4:4 10-bit uncompressed HD-RGB workflows for the most quality-critical applications.

Film-based television and feature film workflow

Avid DNxHD 36 is a low bandwidth HD resolution targeted specifically at the creative editorial workflow. Avid DNxHD 36 is a high-quality offline HD resolution supporting the full 16x9 aspect ratio and is available for 1080p/23.976, 1080p/24 and 1080p/25 projects. Native HD offline editing adds several benefits to the overall workflow such as perfect conform of all effects (compared to working with standard definition 16:9 anamorphic), removes the need for complicated timecode conversions between standard definition frames rates of 30fs and 25fps, tracking of pulldown cadence when in NTSC, single pass

capture of picture and sound, and high enough quality to screen directly without an additional conform step - saving time and money.

The Avid DNxHD 36 data rate is about a third more than standard definition DV25 allowing for massive amounts of footage to be captured. For example, 100,000 feet of 35mm, 4 perf film is ~18.5 hours; when captured at Avid DNxHD 36 it will only require 330 GB of storage.

Avid DNxHD encoding enables a file-based workflow for high-resolution files such as 2K/4K film scans using HD proxies generated in Avid DS or in Media Composer using HD proxy media made with Avid MetaFuze. As part of a digital intermediate workflow, Avid DNxHD provides both visual and metadata information for a frame-accurate file-based conform using high-quality images for screenings and “conform checks” from offline to final mastering.

The following diagram shows the film-based HD workflow for feature film and television using Media Composer Mojo DX with Symphony Nitris DX in an offline/online workflow:

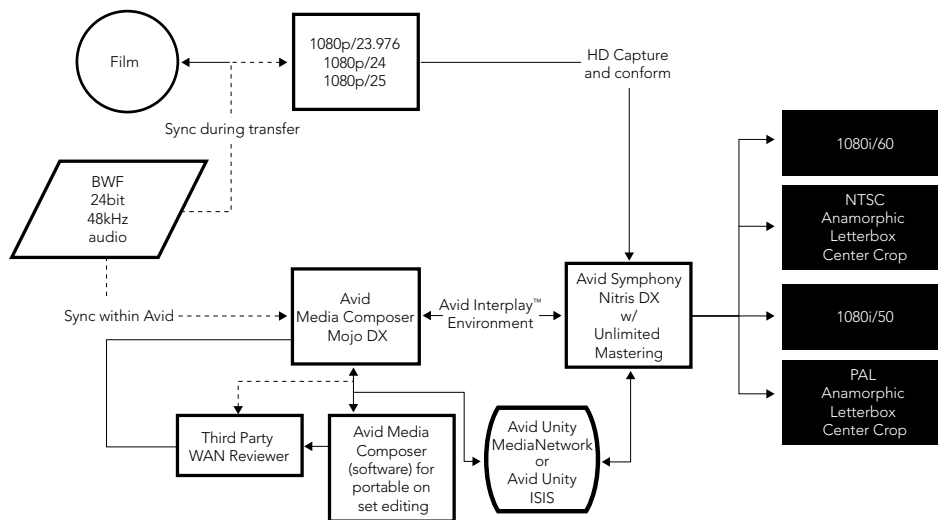

Real-time collaboration with HD resolution

Any of the above workflows can be further enhanced by connecting two or more systems together via an Avid Unity shared media network. One of the key advantages of the Avid DNxHD family is that it allows real-time HD collaboration and workflow that customers currently enjoy today in SD environments using Avid Unity Media Network or

Avid Unity ISIS. By enabling simultaneous media access for all users without the need to copy, push or pull, the overall time spent in post production is reduced while the highest quality picture is maintained.

WAN collaborative solutions can also be provided by using a secure, encrypted delivery system. Projects, bins, and media can easily be assembled and sent to one or more team members with ease of use with feedback and notification.

Creative editorial versus mastering

Avid DNxHD encoding and the ability to mix a variety of HD and SD formats in real time changes the concept of a collaborative offline/online HD workflow. Many productions will realize a benefit of acquiring media once and the ability to share tasks based on personnel, schedules, and room availability. Time spent in recapturing sources is better spent being more creative. Resolution is no longer the defining factor as to how and when a production gets completed. Greater efficiency in the production pipeline can be achieved by dividing the creative tasks more efficiently. This is accomplished by eliminating the redundancy of tracking assets of different resolutions and streamlining the recapture process.

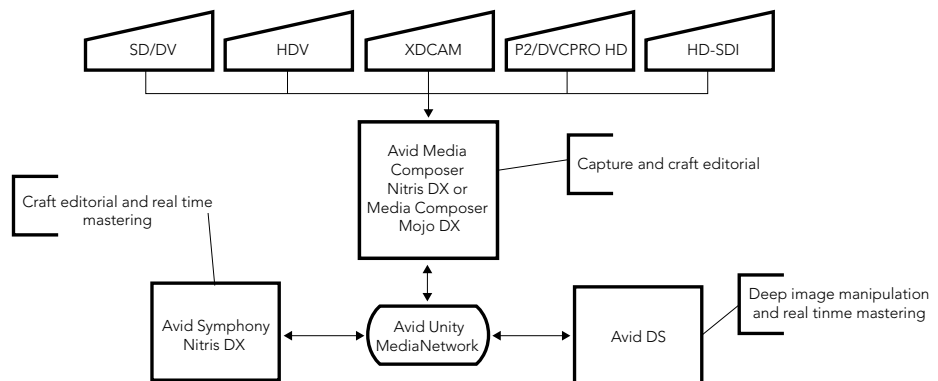

Other workflow enablers

Avid DNxHD

Avid DNxHD is engineered to create mastering-quality HD media at dramatically reduced file sizes. Avid DNxHD allows customers more choices when building workflows because it is the first codec compliant with SMPTE-VC3. More than 30 partners have licensed Avid DNxHD technology which enables you to extend workflows throughout your facility. This compliance also delivers the availability of a new standard for mapping

VC-3 coding units into MXF – making Avid DNxHD encoding the professional standard for file exchange, data archiving and media workflow.

SD and HD combined

Avid Media Composer and Symphony systems allow mixing of SD and HD in the same timeline for matching frame rates. When this scenario is encountered, the output format determines the resolution and up convert or down convert will occur in real time (SD will be up converted to HD in real time or HD will be down converted in real time to SD). This allows for an offline to online “conform check” as well as a real-time proxy while all the elements are being recaptured in the target resolution.

Once an HD sequence has been conformed, the output has both the HD and SD signals available at the same time. In the case of a 1080p/23.976 conform, the SD down-convert also applies a real time 2:3 pulldown insertion. The user also has the choice of three aspect ratios for the SD down convert: Full Height Anamorphic, 16:9 Letterbox, and 4:3 center crop.

Transcode

A user also has the ability to transcode easily between all resolutions with the same frame rate. This is already a popular SD workflow feature using today’s Media Composer systems. Transcoding allows any one resolution to be changed to another resolution automatically rather than recapturing from tapes. Take, for example, an offline workflow where the sources are captured as HD but where the producer, editor, or director wants to take a version of the selects on a laptop. Transcoding would allow the conversion of all selected master clips and sequences to a lower resolution targeted for the laptop.

Appendix A - Project types for Media Composer

Media Composer and NewsCutter project types. HD project types are highlighted.

| Format | HD/SD | Rate/FPS | Units/Second |
|-----------------|--------------|-----------------|---------------------|
| 23.976p NTSC | SD | 23.976 | frames |
| 24p NTSC | SD | 24 | frames |
| 30i NTSC | SD | 29.97 | fields |
| 24p PAL | SD | 24 | frames |
| 25p PAL | SD | 25 | fields |
| 25i PAL | SD | 25 | fields |
| 720p/23.976 | HD | 24 | frames |
| 720p/25 | HD | 25 | frames |
| 720p/29.97 HDV | HD | 29.97 | frames |
| 720p/50 | HD | 50 | frames |
| 720p/59.94 | HD | 59.94 | frames |
| 1080p/23.976 | HD | 23.976 | frames |
| 1080i/50 | HD | 25 | fields |
| 1080i/59.94 | HD | 29.97 | fields |
| 1080i/50 HDV | HD | 25 | fields |
| 1080i/59.94 | HD | 29.97 | fields |
| 1080i/59.94 HDV | HD | 59.94 | fields |
| 1080p/24 | HD | 24 | frames |
| 1080p/25 | HD | 25 | frames |

Appendix B - Avid DNxHD family of resolutions

Each of the project formats have various choices of video resolutions that are available in the media creation settings for capture, titles, import, mixdown, and render.

Avid DNxHD supports both 8-bit and 10-bit images. All HD resolutions use the MXF container format.

The following list of resolutions is supported in Media Composer, Symphony and NewsCutter systems.

| Project Format | Resolution | Frame Size | Bits | FPS | Mb/s | min/GB |
|----------------|------------|-------------|------|--------|------|--------|
| 1080i/59.94 | DNxHD 220x | 1920 x 1080 | 10 | 29.97 | 220 | 0.651 |
| 1080i/59.94 | DNxHD 220 | 1920 x 1080 | 8 | 29.97 | 220 | 0.651 |
| 1080i/59.94 | DNxHD 145 | 1920 x 1080 | 8 | 29.97 | 145 | 0.985 |
| 1080i/50 | DNxHD 185x | 1920 x 1080 | 10 | 25 | 184 | 0.780 |
| 1080i/50 | DNxHD 185 | 1920 x 1080 | 8 | 25 | 184 | 0.780 |
| 1080i/50 | DNxHD 120 | 1920 x 1080 | 8 | 25 | 121 | 1.181 |
| 1080p/25 | DNxHD 185x | 1920 x 1080 | 10 | 25 | 184 | 0.780 |
| 1080p/25 | DNxHD 185 | 1920 x 1080 | 8 | 25 | 184 | 0.780 |
| 1080p/25 | DNxHD 120 | 1920 x 1080 | 8 | 25 | 121 | 1.181 |
| 1080p/25 | DNxHD 36 | 1920 x 1080 | 8 | 25 | 36 | 3.98 |
| 1080p/24 | DNxHD 175x | 1920 x 1080 | 10 | 24 | 176 | 0.814 |
| 1080p/24 | DNxHD 175 | 1920 x 1080 | 8 | 24 | 176 | 0.814 |
| 1080p/24 | DNxHD 115 | 1920 x 1080 | 8 | 24 | 116 | 1.231 |
| 1080p/24 | DNxHD 36 | 1920 x 1080 | 8 | 24 | 36 | 3.98 |
| 1080p/23.976 | DNxHD 175x | 1920 x 1080 | 10 | 23.976 | 176 | 0.814 |
| 1080p/23.976 | DNxHD 175 | 1920 x 1080 | 8 | 23.976 | 176 | 0.814 |
| 1080p/23.976 | DNxHD 115 | 1920 x 1080 | 8 | 23.976 | 116 | 1.231 |
| 1080p/23.976 | DNxHD 36 | 1920 x 1080 | 8 | 23.976 | 36 | 3.98 |
| 720p/59.94 | DNxHD 220x | 1280 x 720 | 10 | 59.94 | 220 | 0.651 |
| 720p/59.94 | DNxHD 220 | 1280 x 720 | 8 | 59.94 | 220 | 0.651 |
| 720p/59.94 | DNxHD 145 | 1280 x 720 | 8 | 59.94 | 145 | 0.985 |
| 720p/50 | DNxHD 185x | 1280 x 720 | 10 | 50 | 175 | .818 |
| 720p/50 | DNxHD 185 | 1280 x 720 | 8 | 50 | 175 | .818 |
| 720p/50 | DNxHD 120 | 1280 x 720 | 8 | 50 | 175 | 1.244 |
| 720p/29.97 | DNxHD 110x | 1280 x 720 | 10 | 29.97 | 110 | 1.30 |
| 720p/29.97 | DNxHD 110 | 1280 x 720 | 8 | 29.97 | 110 | 1.30 |
| 720p/29.97 | DNxHD 75 | 1280 x 720 | 8 | 29.97 | 72 | 2.05 |
| 720p/25 | DNxHD 90x | 1280 x 720 | 10 | 25 | 92 | 1.59 |
| 720p/25 | DNxHD 90 | 1280 x 720 | 8 | 25 | 92 | 1.59 |
| 720p/25 | DNxHD 60 | 1280 x 720 | 8 | 25 | 60 | 2.39 |
| 720p/23.976 | DNxHD 90x | 1280 x 720 | 10 | 23.976 | 88 | 1.566 |
| 720p/23.976 | DNxHD 90 | 1280 x 720 | 8 | 23.976 | 88 | 1.566 |
| 720p/23.976 | DNxHD 60 | 1280 x 720 | 8 | 23.976 | 58 | 2.381 |

Corporate Headquarters 800 949 AVID (2843)

Asian Headquarters + 65 6476 7666

European Headquarters + 44 1753 655999

To find your regional Avid office, visit www.avid.com/contact

©2008 Avid Technology, Inc. All rights reserved. Product features, specifications, system requirements and availability are subject to change without notice. AirSpeed, Avid, Avid DNxcel, Avid DNxHD, Avid Unity, Avid Unity ISIS, Avid Xpress, DigiDelivery, Digidesign, DNxchange, Interplay, Media Composer, NewsCutter, Nitris, and Symphony are either registered trademarks or trademarks of Avid Technology, Inc. or its subsidiaries in the United States and/or other countries. FireWire is a trademark of Apple Computer, Inc., registered in the U.S. and other countries. All other trademarks contained herein are the property of their respective companies.

AHDWWP0408